



MAKE SURE IT'S MARWIN-MADE.<sup>SM</sup>

www.marwincompany.com

# INSTALLATION INSTRUCTIONS

## 200BB SERIES KD POCKET DOOR FRAME

FOR 2" X 4" STUD WALLS

Kit Number	Door Height	Rough Opening Height
KD200BB68	80"	84 ½"
KD200BB70	84"	88 ½"
KD200BB80	96"	100 ½"

### IMPORTANT

Instructions are for a 80" tall door. If door is shorter, lower the header and cut the bottom ends of the steel wrapped stiffeners.

For 1" (25mm) to 1-3/4" (45mm) doors up to 200 lbs. (90kgs)

With 1-3/4" (45mm) Doors, order and use an Adapter Kit or modify

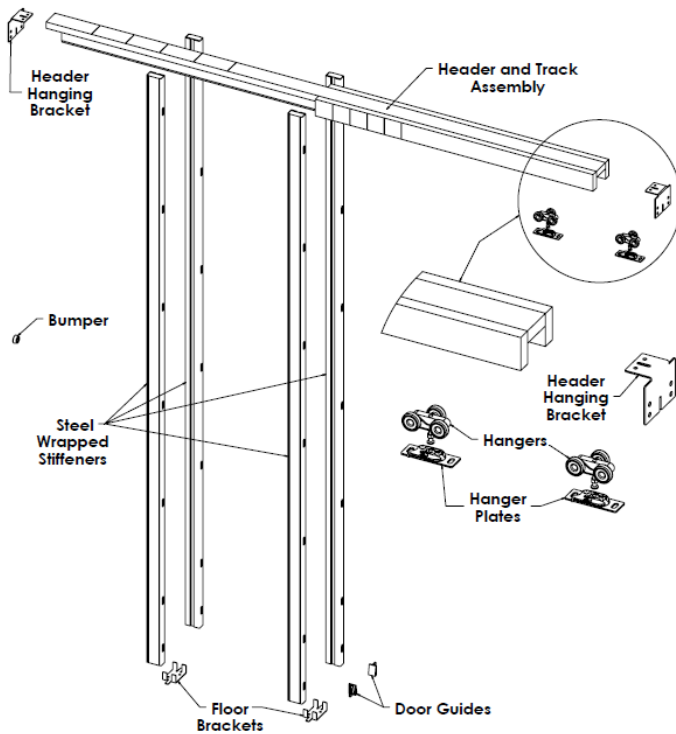

### This Kit Contains:

- 1 Header and Track Assembly
- 2 Header Hanging Brackets
- 4 Steel Wrapped Stiffeners
- 2 Floor Brackets
- 1 Hardware Bag Contains
  - 2 3-Wheel Hangers
  - 2 Hanger Plates
  - 2 Door Guides
- 1 Bumper
- 1 Wrench
- Screws

### STEP 1 CONSTRUCT ROUGH OPENING

Ensure Header is level, plumb, and square with the studs. Minimum height is 84 ½" (door height plus 4 ½"), 88 ½" for a 7/0 kit and 100 ½" for an 8/0 kit. The width is 2 times the door width plus 1 ¼". See chart above for rough opening height.

### STEP 2 MEASURE AND MARK

Measure up from the finished floor 80 ¾" or from the sub-floor to 81 ½". This will give ¾" to 1 ½" clearance under the door. Mark each rough stud and drive a flat head nail in the center, leaving 1/8" protruding. (The frame header brackets will rest on these nails)

Snap 2 chalk lines on the floor even with the side jambs.

### Preparing for Pocket Door Installation

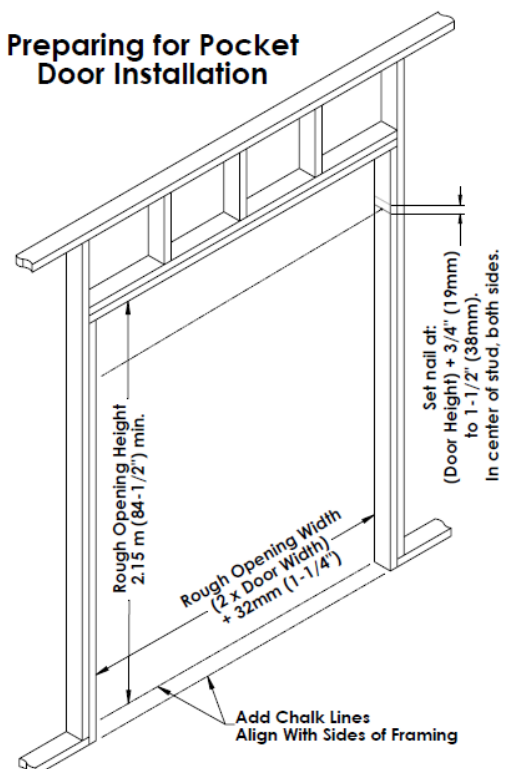

### STEP 3 PREPARE HEADER AND TRACK ASSEMBLY

The header and track in this kit will fit a 36" wide door without any modification. Both the header and track will need to be cut for any door width less than 36". The header is marked accordingly.

#### TRIMMING INSTRUCTIONS:

1. Cut the wood header (top marked side) at the size marking for your door width.  
**CAUTION: Do not cut the track.**
2. Measure 1 3/8" from the trimmed header end and cut the track at this point.  
(The track should be 1 3/8" shorter than the header)  
**CAUTION: Do not cut the header board or the track.**
3. Turn the header on its side and cut the nailing board ONLY at the size marking for your door width. Do this on both sides.  
**CAUTION: Do not cut the header board or the track.**

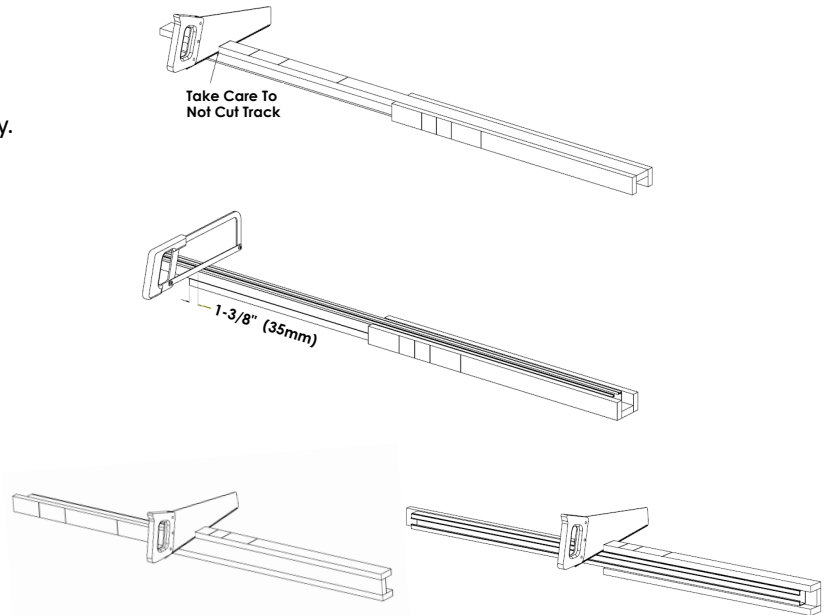

### STEP 4 ATTACH HEADER HANGER BRACKETS

Attach a Header Hanger Bracket to each end of the Header. Using 2 screws on the small side of the bracket, ensure that the first bracket is affixed up against the nailing boards on one end and the screws are inserted through the holes. Then line up the other bracket onto the pocket end of the header, flush with the end of the header, and affix it with one screw in the end of the slot closest to the end of the header. Do not tighten screw as adjustment may be required later.

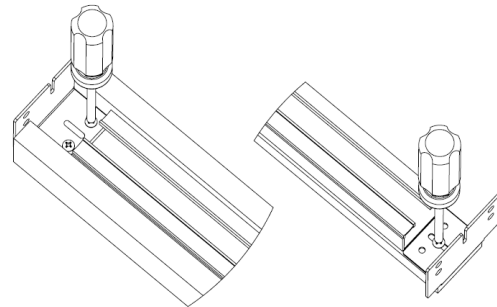

### STEP 5 INSTALL HEADER ASSEMBLY

Determine which side of the opening will be the doorway. The header assembly should be installed with the nailing boards in the doorway. Slide the slots in both ends of the header hanging brackets onto the protruding nails in the studs. Check to make sure the header is level. Set the nails and drive additional nails into the remaining holes of the brackets.

#### Optional Solid Door Installation:

Remove every other screw and replace with 3 1/2" screws to affix assembly into rough header frame.

### Installation of Header and Track Assembly

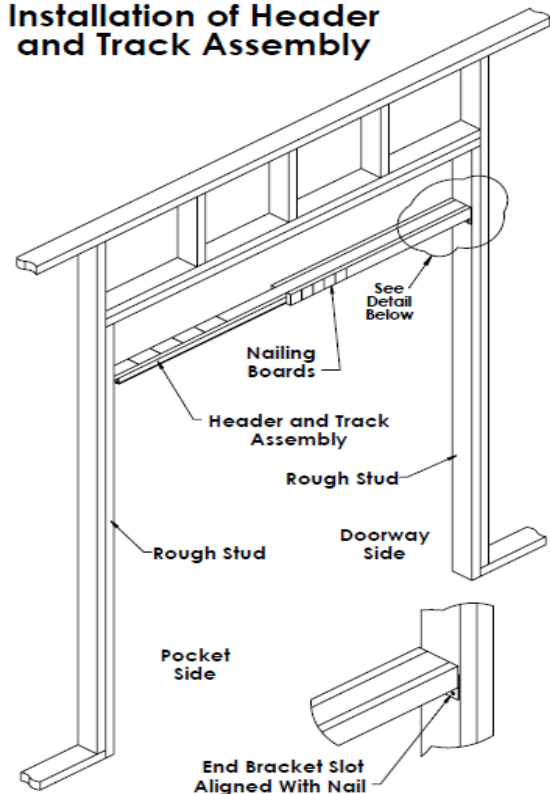

## STEP 6 CHECK DOOR THICKNESS

When properly installed without modifications, this pocket door frame allows 2" (51mm) free space for the door between the metal stiffener studs. A 1 3/8" (35mm) door would leave 5/16" (8mm) clearance on each side. A 1 3/4" (45mm) door would leave 1/8" (3mm) clearance on each side.

**PLEASE NOTE: For a door thickness over 1 3/4" (45mm), the floor plates may be cut and spread apart to suit. Shims would have to be inserted between the header assembly as well as adding additional wood to the nailing boards to match the new overall width of the metal stiffener stud spacing.**

---

## STEP 7 FLOOR PLATE PLACEMENT

TEMPORARILY lay down the floor plates between the chalk lines, one approximately in the center of the opening the other approximately halfway in between it and the rough stud on the pocket side.

**PLEASE NOTE: DO NOT affix the floor plates to the floor at this point.**

---

## STEP 8 ATTACH THE METAL STIFFENER STUDS

Orient the metal stiffener studs so that the exposed wood surfaces face away from the pocket and towards the opening side to accept nails or screws for the wall board and trim.

Engage a pair of metal stiffener studs, properly oriented, onto the floor plate at the pocket opening, then butt them up to the nailing boards and nail them to the header. Nail the second pair of metal stiffener studs to the header midway between the first pair of metal studs and the rough stud on the pocket side. Re-position the floor plates between the chalk lines and plumb the metal studs, making sure they are vertical and square.

Fasten the floor plates to the floor.

---

## STEP 9 INSTALL THE BUMPER

Install the bumper halfway up the rough stud on the pocket side.

---

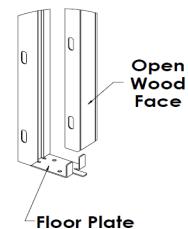
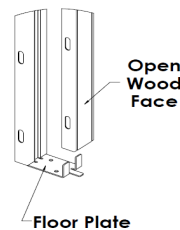
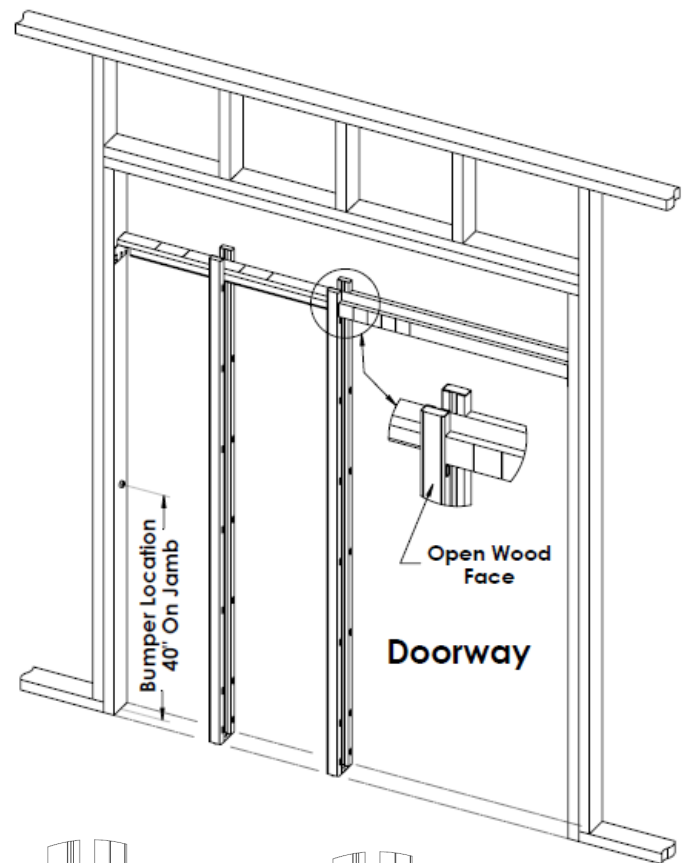

## STEP 10 APPLY WALL MATERIAL

Apply the wall board to both sides of the frame and header. To assist in securing wall material with a firm nailing surface, temporarily insert a 2-1/8" (54mm) wide board between the metal stiffeners.

**WARNING: Use nails or screws no longer than necessary. Nails or screws must not protrude into the pocket cavity. Doing so will risk damage to the door.**

---

## STEP 11 SEAL DOOR

To help prevent door warpage, guard against moisture absorption by sealing ALL edges of the door with paint or sealing stain.

---

## STEP 12 MOUNT DOOR PLATES AND INSERT ROLLERS

Mount the door plates on the top edge of the door, 2" from each end. Ensure that the slots face the same direction.

Ensure that the hanger bolt is in its lowest position on the 3-wheel rollers. Insert the rollers into the track of the header as illustrated, alternating the 2 wheel side from the 1 wheel side.

---

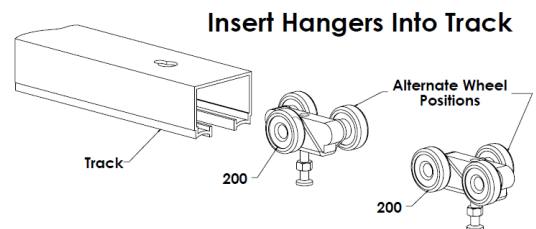
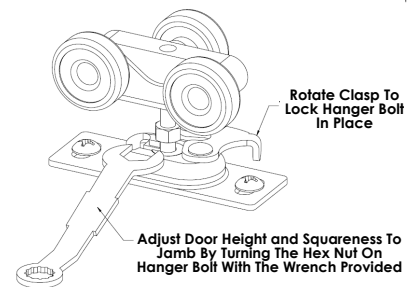
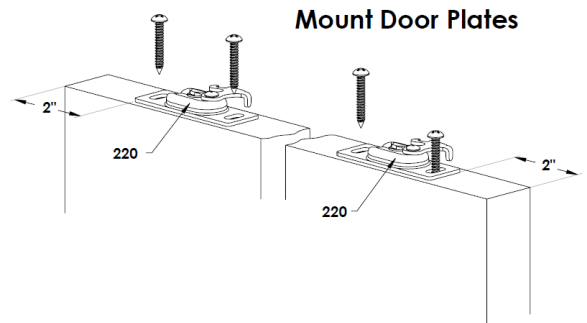

## STEP 13 HANG THE DOOR

Hang the pocket end of the door first by engaging the hanger into the slot on the side of the mounted hanger plate, then repeat for the hanger and plate on the opening end of the door. Close the clasp on each hanger plate to lock the hanger bolt into position.

Adjust the door for height above the floor and for squareness to the solid jamb, by turning the hex portion of the hanger bolt with the wrench provided.

---

## STEP 14 INSTALL FINISH JAMBS, SPLIT HEADER, & CASING

Install finish jambs, split header and casing (all not provided).

Nail vertical finish jambs to the wood surface side of each metal stiffener stud at the pocket opening, ensuring the outer edge is flush with the face of the wall board.

Install a jamb to the wall on the opening side.

Fasten split header on the lock lever side of the mounting plate on top of the door with screws for future door removal or adjustment.

Install the finish trim casing. DO NOT nail the header finish trim to the split header, affix with screws. Door stop trim can be affixed to split header with finish nails so that header trim can be removed later for door adjustment or removal without damage.

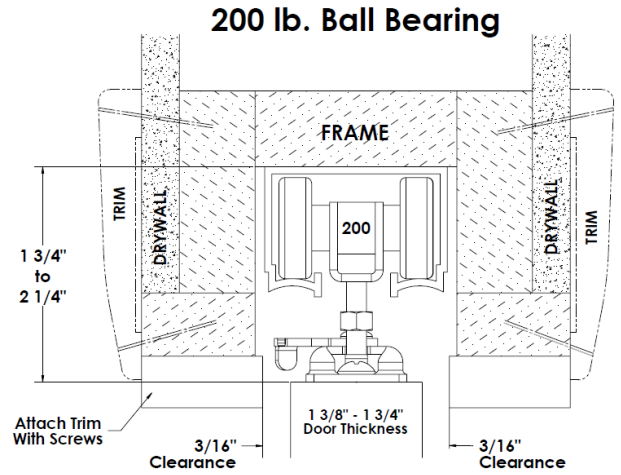

---

## STEP 15 INSTALL DOOR GUIDES

Install the door guides by attaching them to the split side jambs at the bottom of the door with the screws provided to ensure door is held and slides in the center of the opening.

